

# Azura Full-Scale Design

# 2018

## Test Plan for Wave Tank Testing: Advanced Controls Project



Northwest Energy Innovations

10/24/2018

Project Title: "Advanced Control of the  
Azura Wave Energy Device"

DE-EE0007693

## TABLE OF CONTENTS

1. Introduction .....	3
2. Objectives.....	3
3. Test Article .....	3
4. Test Facilities.....	4
5. Schedule.....	5
6. Test Setup .....	5
7. Test Procedures .....	6
7.1. Wave tank calibration .....	6
7.2. Irregular wave tests .....	7

## 1. INTRODUCTION

This document describes wave tank testing of advanced control algorithms that will be performed with a 1:15 scale model of the commercial scale Azura wave energy converter in late fall, 2017. These tests will be performed at the Harold Alfond W2 Ocean Engineering Laboratory at the University of Maine - Orono (UMO). The primary objective of these tests will be to measure Azura output power with Model Predictive Control (MPC) implemented. These tests will start soon after the conclusion of baseline tests of the same Azura 1:15 scale model without MPC. Those tests, described in the NWEI document *Test Plan for Wave Tank Testing Fall 2017*, will be performed at the same UMO facility with the same hardware test setup. The results of the MPC tests will be compared to the results of the earlier baseline tests to determine the improvement in output power that results from the addition of MPC.

## 2. OBJECTIVES

1. Collect data in irregular waves that can be used to predict full-scale device performance in six representative bins of the device power matrix with MPC control of an ideal direct-drive PTO.
2. Collect data in irregular waves that can be used to predict full-scale device performance in six representative bins of the device power matrix with MPC control of the Azura hydraulic PTO.

## 3. TEST ARTICLE

The test article will be a 1:15 scale model of the NWEI full-scale device. See Figure 3-1 for a CAD rendering of this model. This tank model is described in detail in the NWEI document “Wave Tank Model Specification”. No modifications are planned for this model between the conclusion of baseline testing (per NWEI document *Test Plan for Wave Tank Testing Fall 2017*) and the beginning of these tests.

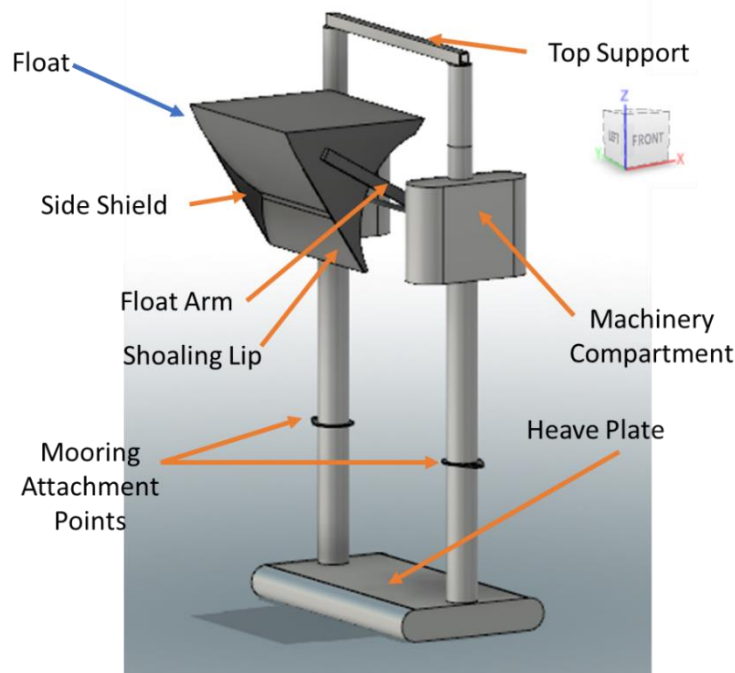

Figure 3-1 Rendering of NWEI tank model

#### 4. TEST FACILITIES

Testing will be performed at the Harold Alfond W<sup>2</sup> Ocean Engineering Laboratory at the University of Maine Advanced Structures and Composites Center in Orono, Maine. Basic information about this facility is described below; further information is provided at the following web site: <https://composites.umaine.edu/key-services/offshore-model-testing/>.

Table 4-1 Harold Alfond W<sup>2</sup> Ocean Engineering Laboratory details

Length	30 m
Width	9 m
Max depth	4.5 m
Wave period range	0.5-5 s
Max wave height	0.8 m

This facility is equipped with a high-performance rotating wind machine over a wave basin. The wave basin has a 16-paddle wave generator at one end, a beach at the other end, and an adjustable floor.

## 5. SCHEDULE

NWEI has budgeted for four days of advanced controls debugging and tuning followed by three days of irregular wave testing, then a day for removal. The expected timeline for these tests is shown in Figure 5-1. This schedule assumes that 1) these tests are performed shortly after the conclusion of baseline tests and the test setup is left in place following baseline tests, 2) the test setup is identical to that used for baseline tests, and 3) tank calibration data from baseline irregular wave cases can be used for these tests.

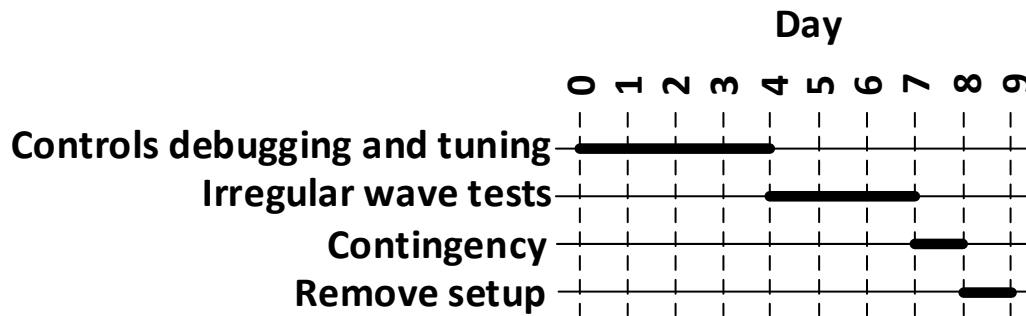

Figure 5-1 Timeline for Azura controls wave tank tests

## 6. TEST SETUP

The hardware test setup will be identical to that used for baseline testing and is described in the NWEI document *Test Plan for Wave Tank Testing Fall 2017*. See Figure 6-1 showing the data acquisition and control systems. This diagram is identical to that used for the baseline tests. MPC software and hardware-in-the-loop software simulating a hydraulic PTO will be loaded into the NWEI Speedgoat controller for these tests via the NWEI PC. Several different MPC configurations will be tested.

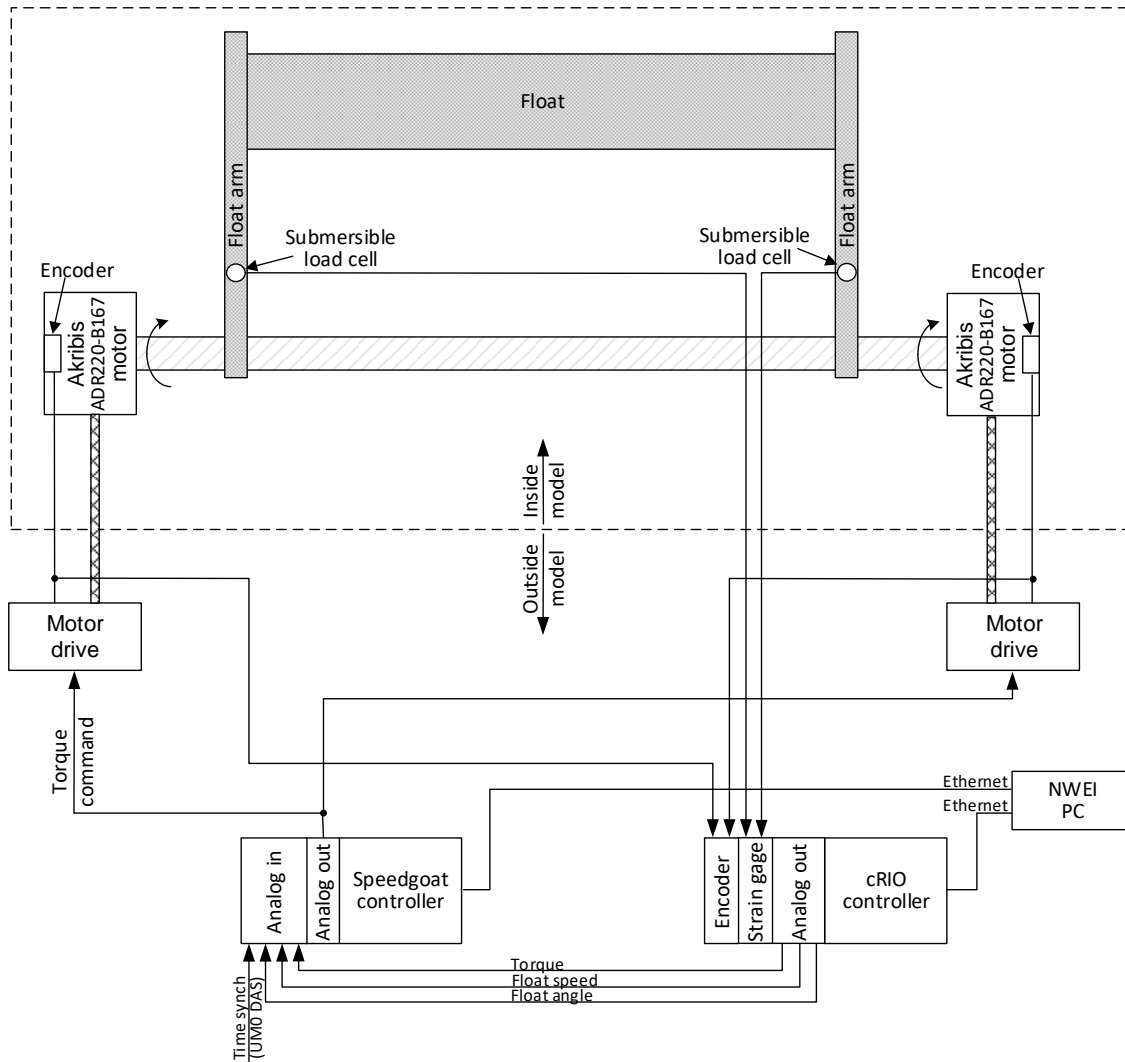

Figure 6-1 Data acquisition and tank model control for NWEI tank test

## 7. TEST PROCEDURES

### 7.1. Wave tank calibration

Because the wave cases used for these tests will be identical to those used for baseline tests (see NWEI document *Test Plan for Wave Tank Testing Fall 2017*), baseline calibration data will be used and calibration will not be repeated for these tests.

### 7.2. Driven PTO test

These tests will be performed during time allocated to controls debugging and tuning to validate PTO performance, and to measure the actuator transfer function between controlled PTO torque and tank model motion.

The Speedgoat controller will be set up to output a white noise torque command to the motor drive (see Figure 6-1) for these tests. Since the tank model PTO is designed for four quadrant control of the PTO generators, the generators are capable of the motoring action needed for this test. A white noise spectra and the corresponding time series torque command will be determined by NWEI prior to performance of the test. The duration of this test is expected to be about 15-30 min. The tank will be allowed to settle before the test is started. While the white noise torque command is applied to the PTO generators, data will be collected from all sensors listed in Table 6-1 of the NWEI document *Test Plan for Wave Tank Testing Fall 2017*, including Qualisys motion data. The resulting data will be analyzed to calculate transfer functions between commanded torque and float arm torque, and commanded torque and device motions.

### 7.3. Irregular wave tests

See Table 7-1 for a list of irregular wave cases that will be run. These six wave cases are also used for baseline testing (see NWEI document *Test Plan for Wave Tank Testing Fall 2017*). At the onset of testing, tests will be run in various wave conditions and control configurations to debug the control software and real-time instrumentation feedback. Once thoroughly debugged, final runs will be made for each wave case and each control configuration, one with MPC and an ideal direct-drive PTO and one for controlling a hydraulic PTO. The hydraulic PTO will be implemented as a hardware-in-the-loop simulation in Speedgoat controller software. Each controller will utilize parameters from each test that were determined to be optimal from simulations performed prior to testing. Experimental results will be compared to simulation results at the conclusion of each test. Based on observations made during the debugging tests and final tests the test engineer will decide if additional tests with different control parameters are necessary.

Table 7-1 Bulk Wave statistics for Irregular wave runs

Case	Significant Wave Height (m)		Energy Period (s)		Notes
1	1.25	0.083	7.5	1.94	Bretschneider (unidirectional)
2	1.75	0.117	6.5	1.68	Bretschneider (unidirectional)
3	1.75	0.117	9.5	2.45	Bretschneider (unidirectional)
4	2.25	0.150	7.5	1.94	Bretschneider (unidirectional)
5	2.25	0.150	11.5	2.97	Bretschneider (unidirectional)
6	3.25	0.217	8.5	2.19	Bretschneider (unidirectional)

\* Note, values in shaded cells are full scale values, unshaded at tank scale.

The following test sequence will be used for the irregular wave runs:

1. Configure Speedgoat software for MPC control of a direct drive PTO.
2. Start data acquisition systems. Record start time, wave spectra, and damping setting.
3. Start wave generation; wait until tank settles to desired condition (< 1 min).
4. Operate for 15 minutes (a single repeat period of the wave elevation time series).

5. Stop data acquisition.
6. Perform basic data quality checks to ensure data was collected and wave tank PTO was functioning properly.
7. Configure Speedgoat software for MPC configuration #1 control of the hydraulic PTO.
8. Repeat steps 2-6 with wave cases #1-6.

Note: The performance of each MPC configuration will be evaluated after testing each wave case; configurations with poor performance may not be tested in all wave cases.

To ensure the model PTO and torque measurements are properly functioning for each test, at the conclusion of each test a scatter plot of the commanded torque vs. measured torque will be displayed on the supervisory computer. A linear regression analysis showing the slope of the correlation and the correlation coefficient will be displayed. If the slope or the correlation coefficient deviates significantly from 1.0, that indicates a problem with either the torque measurement or the model PTO, indicating a problem with the test.